



浙江珠城科技股份有限公司

ZHEJIANG ZUCH TECHNOLOGY CO., LTD

产品系列

MWP 防水系列连接器

文件名称
Document name

产品应用规格书
Product Application Specification

页码 page

1-7

MWP 防水系列连接器

MWP Waterproof Series Connectors

目录

Index

1. 索引 Index
2. 产品名称及型号 Product specifications
3. 端子适用导线 Terminal applicable wire
4. 产品安装基准 Product installation benchmark
5. 产品压接指导 Product Crimp guide
6. 端子装配指导 Terminal Assembly Instructions

文件修订履历(Modify history)

标记 Tag	修订日期 revision date	修订内容摘要 Revision content	修订者 reviser	备注 Note
A00	2022.05.08	初版编制	鱼栋冬	

制定: Prepared by:	鱼栋冬	审核: Reviewed by:	李涛涛	批准: Approved by:	王春生
编号: Document Number:	ZC-PAS-060	版本: Revision:	A00	发行日期: Release Date:	2022.05.08



浙江珠城科技股份有限公司

ZHEJIANG ZUCH TECHNOLOGY CO., LTD

产品系列

MWP 防水系列连接器

文件名称
Document name

产品应用规格书
Product Application Specification

页码 page

2-7

1. 索引 Index

本应用规格书介绍了我司 MWP 防水系列的线对线产品型号、产品适用导线、产品安装基准、产品压接指导。

This application specification introduces the wire-to-wire product model of our MWP waterproof series, the applicable wires for the product, the product installation standard, and the product crimping guide.

2. 产品名称及型号 Product specifications

按本公司一般产品叫法命名：

全套连接器的插入端称之为公端，被插入端称之为母端或者针座，公端的主体塑件称之为孔座，一般情况下，公端内的端子称之为簧端子，母端的主体塑件称之为母座，母端内的端子称之为针端子，两端的防脱插销称之为锁片（两端锁片不一时，公端对应的锁片称之为公锁片，母端对应的锁片称之为母锁片）。

Product Naming:

Male side means the inserting side of the connector or plug; female side means the inserted side or header side. Major housing of the male side is named plug housing, and the mating terminal is named socket terminal. Major housing of the female side is named receptacle housing, and the mating terminal is named pin terminal, and the terminal position assurance for both housings are named retainer. (If the retainers for both side housing are different, the one for plug housing is named male retainer, and the other one for receptacle housing is named female retainer.)

连接器名称 Connector	部件名称 Part Name	产品型号 Part No.	互配 Mutual matching	材质 Material	表面处理 Surface
公端 Plug	MWP-nP	AP7001A-nY/0101	AR7001A-nY (N)	PA66	/
母端 Receptacle	MWP-nR	AR7001A-nY (N)	AP7001A-nY	PA66	/
	SL 簧	TP3970J-3	AP7001A-nY	磷铜 Phosphorus bronze	镀锡 Tin-plated
	SL 针	TR3970J-3	AR7001A-nY (N)	黄铜 Brass	镀锡 Tin-plated



浙江珠城科技股份有限公司

ZHEJIANG ZUCH TECHNOLOGY CO., LTD

产品系列

MWP 防水系列连接器

文件名称
Document name

产品应用规格书
Product Application Specification

页码 page

3-7

3. 端子适用导线 Terminal applicable wire

产品名称 Part Name	端子型号 Part No.	适用电线范围 Wire	电线外皮 OD Insulation diameter
SL 簧	TP3970J-3	AWG18-22 (0.75 ² ~ 0.3 ²)	φ 2.1-φ 2.5
SL 针	TR3970J-3	AWG18-22 (0.75 ² ~ 0.3 ²)	φ 2.1-φ 2.5

4. 产品安装基准 Product installation benchmark

4.1 AR7001A-2Y

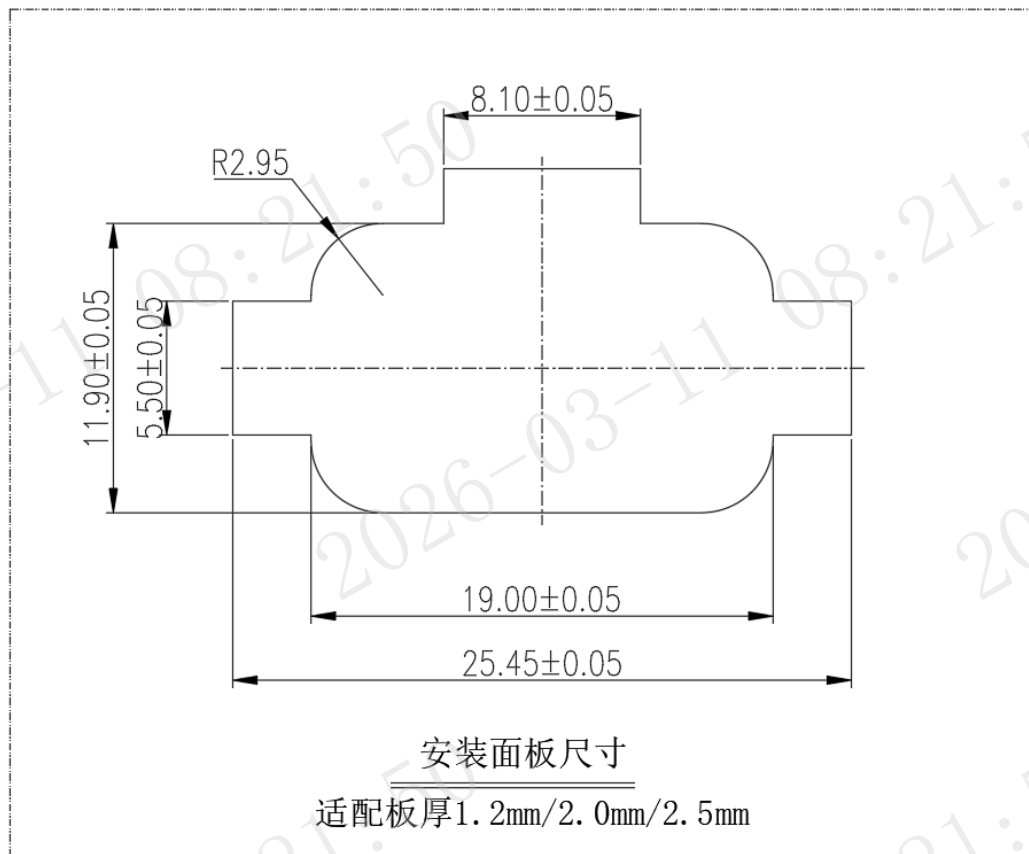

Adaptation board thickness 1.2mm/2.0mm/2.5mm



浙江珠城科技股份有限公司

ZHEJIANG ZUCH TECHNOLOGY CO., LTD

产品系列

MWP 防水系列连接器

文件名称
Document name

产品应用规格书
Product Application Specification

页码 page

4-7

5. 产品压接指导 Product Crimp guide

5.1 一般压接要求 General crimping requirements

压接 Crimp

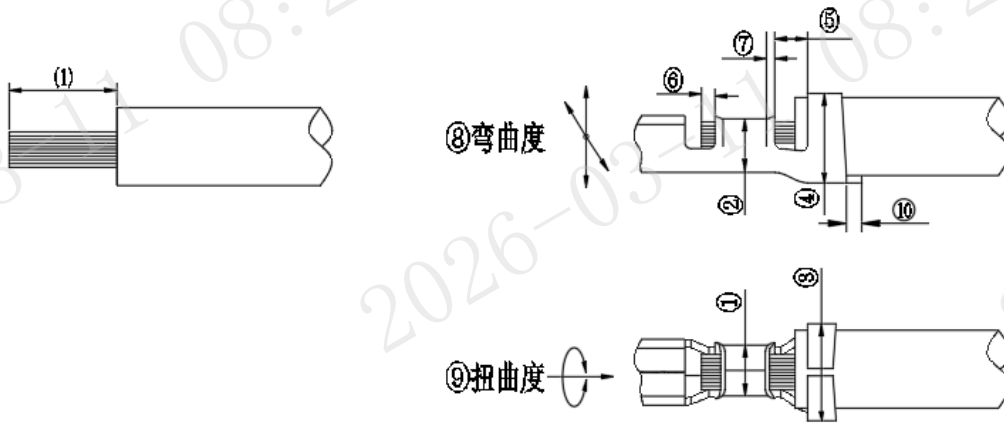

序号 NO.	压接检查要素 Crimping inspection elements	技术要求 Requirement
(1)	导线剥线长度 Strip length	3.3+/-0.1mm.
①	线芯压接宽度 (CCW) Conductor crimping width	见表1 See table 1
②	线芯压接高度 (CCH) Conductor crimping hight	见表1 See table 1
③	线被段压接宽度 (ICW) Insulation crimping width	见表1 See table 1
④	线被段压接高度 (ICH) Insulation crimping hight	见表1 See table 1
⑤	压线脚衔接段 Transition Area	线芯和线皮需同时可见 Conductors and wire insulation both visible in translation area.
⑥	导线末端漏出长度 Wire Brush	0.6+/-0.2mm
⑦	喇叭口 Rear Bellmouth	喇叭口必须可见且不可压伤线芯 The rear bellmouth must be visible and cannot crush the wire core
⑧	压接后弯曲度 Straightness	四向弯曲度 $\leq 3^\circ$ Four-way bending $\leq 3^\circ$
⑨	压接后扭曲度 Twist and Roll	$\leq 3^\circ$
⑩	余料长度 Surplus length	0-0.2mm



浙江珠城科技股份有限公司

ZHEJIANG ZUCH TECHNOLOGY CO., LTD

产品系列

MWP 防水系列连接器

文件名称
Document name

产品应用规格书
Product Application Specification

页码 page

5-7

5.2 端子压接参数 Terminal crimping parameters

型号 part No.	适用线型 Wire	压接宽度 (CW) CCW	压接高度 (CH) CCH	压接宽度 (CW) ICW	压接高度 (CH) ICH
TP3970J-3	AWG18 (0.75 ²)	1.78±0.05	1.10±0.05	2.0±0.05	2.1 MAX.
	AWG20 (0.5 ²)	1.78±0.05	1.00±0.05	2.0±0.05	2.1 MAX.
TR3970J-3	AWG22 (0.3 ²)	1.78±0.05	0.90±0.05	2.0±0.05	2.1 MAX.

表 1 压接参数 (可参考)

Table 1 Crimp parameters (for reference)

5.3 检测方法 Check method

5.3.1 尺寸检查:如图一, A 为线芯段测量位置, B 为线被段测量位置。

5.3.1 Dimension inspection: as shown in Figure 1, A is the measurement position of core section and B is the measurement position of insulation section.

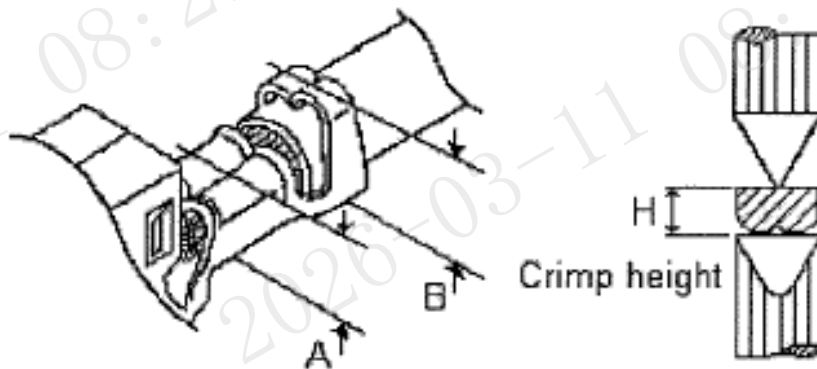

图一 Figure one

测量 A 尺寸时, 应以千分尺测量, 测量区域为压接形状的正中位置, 以保证测量值的准确性, 如图一右侧视图所示.

测量结果参考“表 1”

测量 B 尺寸时, 可用游标卡尺测量, 外形尺寸参考“表 1”即可.



浙江珠城科技股份有限公司

ZHEJIANG ZUCH TECHNOLOGY CO., LTD

产品系列

MWP 防水系列连接器

文件名称
Document name

产品应用规格书
Product Application Specification

页码 page

6-7

Use a micro caliper to measure dimension A, to assure the accuracy of the conductor crimping height measurement, measure the crimp height at the center of barrel as show in the right of Figure 1, the measurement shall be in compliance with table 1.

Use a vernier caliper to measure dimension B, the measurement shall be in compliance with table 1.

5.3.2 剖面分析 Crimping cross section analysis.

线芯段要求:

端子在制作剖面时, 应注意避开端子本身的浅槽, 应垂直压线脚轴线.

Wire conductor requirement after crimping:

When making the cross section, make sure to keep away from the serration area of the terminal, and the cross section shall be vertical to the axis.

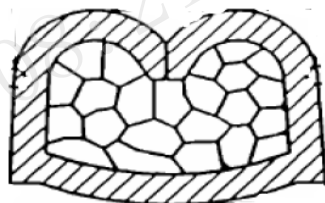

图二 (参考图片)

1. 压接剖面应无孔隙, 导线芯数等于压接前的芯数, 每根线芯均应发生变形;
2. 不可有孤岛现象.

1. Cross section must be without hole, the number of cored wires shall be same to the qty before the crimping, and the every cored wire shall be deformed after crimping.

2. Isolated island phenomenon is not allowed.

线被段要求:

如下图所示, 端子压线脚应固定导线, 且不可刺入线被接触芯线。(图示为参考图)

Wire insulation requirement after crimping:

The insulation barrel shall hold the lead wire securely without thrust into the wire insulation



浙江珠城科技股份有限公司

ZHEJIANG ZUCH TECHNOLOGY CO., LTD

产品系列

MWP 防水系列连接器

文件名称
Document name

产品应用规格书
Product Application Specification

页码 page

7-7

and damage the cored wire. (The picture is a reference picture)

备注：以下均为参考图片图示，满足相关规定的压接要求即可。

Note: The following are all reference pictures and illustrations, and the crimping requirements of the relevant regulations are sufficient.



图三 绝缘压接参考图

6. 端子装配指导 Terminal Assembly Instructions

将端子装入连接器之后，需要借助外力辅助将锁片从预装位置压入锁定位置，锁定时，应能听到咔哒声。（如果没有压入锁定位置，则连接器无法满足防水功能）

After the terminal is installed in the connector, an external force is required to press the locking tab from the pre-installed position into the locked position, and an audible click should be heard when locking. (If it is not pressed into the locked position, the connector cannot meet the waterproof function)

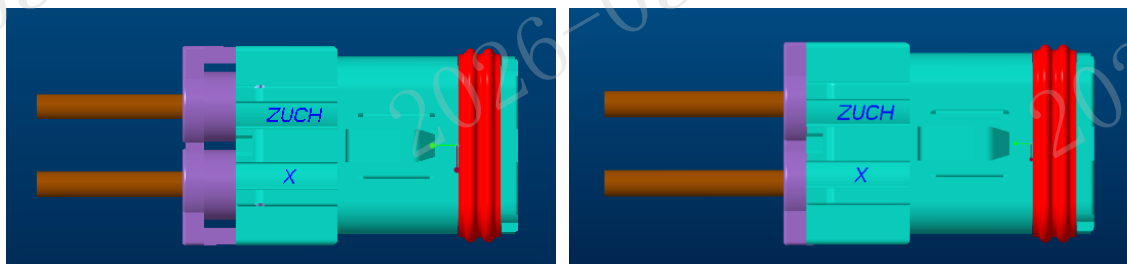

预装位置
pre-installed position

锁定位置
locked position