



浙江珠城科技股份有限公司

ZHEJIANG ZUCH TECHNOLOGY CO., LTD

产品系列

XH 系列

文件名称
Document name

产品应用规格书
Product Application Specification

页码 page

1-10

XH 系列 (XH Series)

目录

Index

1. 简介 Interduction
2. 产品描述 Product Description
3. 针座安装基准 Installation reference of header
4. 端子适用导线 Applicable conductor of terminal
5. 产品压接指导 Product crimping guidance

文件修订履历 (Modify history)

标记 Tag	修订日期 Revision date	修订内容摘要 Revision content	修订者 Reviser	备注 Note
1	2022/11/25	更换模板格式 Change format	朱宗安	
2	2024/06/20	新增贴片产品安装基准	曾令青	
3	2024/11/20	新增沉板贴片产品安装基准	曾令青	
4	2025/08/20	新增规格	曾令青	

制定: Prepared by:	曾令青	审核: Reviewed by:	覃丽	批准: Approved by:	王春生
编号: Document Number:	ZC-PAS-012	版本: Revision:	A04	发行日期: Release Date:	2024. 11. 20

文件编号: ZC-PAS-012



浙江珠城科技股份有限公司

ZHEJIANG ZUCH TECHNOLOGY CO., LTD

产品系列

XH 系列

文件名称
Document name

产品应用规格书
Product Application Specification

页码 page

2-10

1. 简介 Interduction

本应用规格书介绍了我司 XH 系列的单排线对板产品的产品型号、产品安装基准、端子的适用导线和压接指导。

This specification covers the requirements for application of XH series single row wire-to-board interconnections, include part No., product installation basis, applicable conductor and crimping instructions for terminals.

2. 产品描述 Product Description

按本公司一般产品叫法命名：

全套连接器的插入端称之为公端或插头，被插入端称之为母端或者针座，公端的主体塑件称之为孔座，公端内的端子称之为簧端子，母端的主体塑件称之为母座，母端内的端子称之为针端子，两端的防脱插销称之为锁片（两端锁片不一样时，公端对应的锁片称之为公锁片，母端对应的锁片称之为母锁片）。按此名称对应产品型号如下：

Product Naming:

Male side means the inserting side of the connector or plug; female side means the inserted side or header side. Major housing of the male side is named plug housing, and the mating terminal is named socket terminal. Major housing of the female side is named receptacle housing, and the mating terminal is named pin terminal, and the terminal position assurance for both housings are named retainer. (If the retainers for both side housing are different, the one for plug housing is named male retainer, and the other one for receptacle housing is named female retainer.)

连接器名称 Connector name	部件名称 Part Name	产品型号 Part No.	材质 Material	备注 Notes
插头 Plug	孔座 Plug housing	HP2502J-Ny/****	PA66	N. A
	孔座(带锁扣) Plug housing (with lock buckle)	HP2502J-B-nY/****	PA66	N. A
	簧端子 Socket terminal	TP2502J-****	磷铜 Phosphorus bronze	镀锡 Tin-plated
	锁片 Retainer	HC2502J-nS/****	PA66	N. A



浙江珠城科技股份有限公司

ZHEJIANG ZUCH TECHNOLOGY CO., LTD

产品系列

XH 系列

文件名称
Document name

产品应用规格书
Product Application Specification

页码 page

3-10

针座(带扣) SMT Header (Latch)	立式贴片针座 Top entry header	HWT2502J-B-nVA/****	LCP、PA9T 黄铜 Brass
	卧式贴片针座 Side entry header	HWT2502J-B-nWA/****	
	卧式贴片全包针座 Side entry header	HWT2502F-B-nWA/****	
	A 型卧式贴片针座 A Side entry header	HWT2502A-B-nWA/****	
	H 型卧式贴片针座 H Side entry header	HWT2502H-B-3WA/****	
针座 SMT Header	立式贴片针座 Top entry header	HWT2502J-nVA/****	镀锡 Tin-plated
	H 型卧式贴片针座 H Side entry header	HWT2502H-2WA/****	
沉板针座 SMT Sinking Header	C 型卧式贴片沉板针座 C Side entry header (Sinking)	HWT2502C-B-3WA/****	
针座 Header	立式针座 Top header	HW2502J-nA/****	PA66 黄铜 Brass
	立式针座(带扣) Top header (Latch)	HW2502J-B-nA/****	
	立式针座(防呆) Top header(Stay alert)	HW2502J-D-nA/****	
	立式针座(带扣防呆) Top header (Latch Stay alert)	HW2502J-BD-nA/****	
	卧式针座 Side entry header	HW2502J-nQA/****	
	卧式针座(带扣) Side entry header (Latch)	HW2502J-B-nQA/****	



浙江珠城科技股份有限公司

ZHEJIANG ZUCH TECHNOLOGY CO., LTD

产品系列

XH 系列

文件名称
Document name

产品应用规格书
Product Application Specification

页码 page

4-10

3. 针座安装基准 Installation reference of header

立式安装

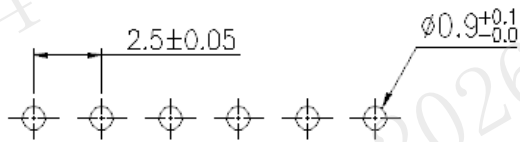

板孔尺寸参考 板厚1.6mm
Dimension reference, plate thickness 1.6 mm

立式防呆柱安装

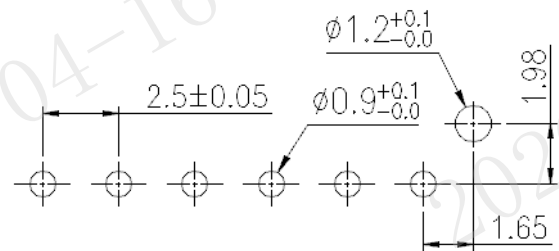

板孔尺寸参考 板厚1.6mm
Dimension reference, plate thickness 1.6 mm

卧式安装

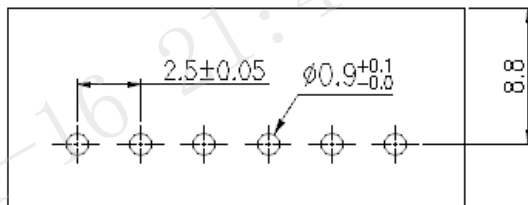

板孔尺寸参考 板厚1.6mm
Dimension reference, plate thickness 1.6 mm

立式贴片安装

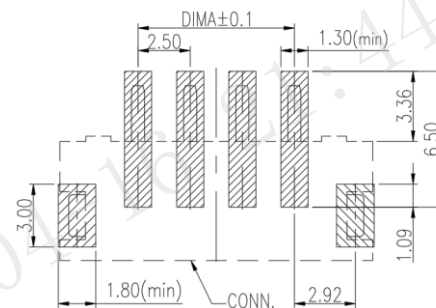

Recommended PCB Layout
Thickness=1.6

卧式贴片安装（带扣、不带扣、A型带扣）

2位H型卧式贴片安装



浙江珠城科技股份有限公司

ZHEJIANG ZUCH TECHNOLOGY CO., LTD

产品系列

XH 系列

文件名称
Document name

产品应用规格书
Product Application Specification

页码 page

5-10

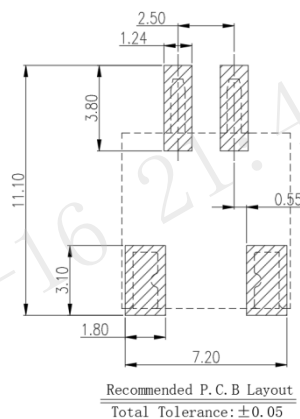
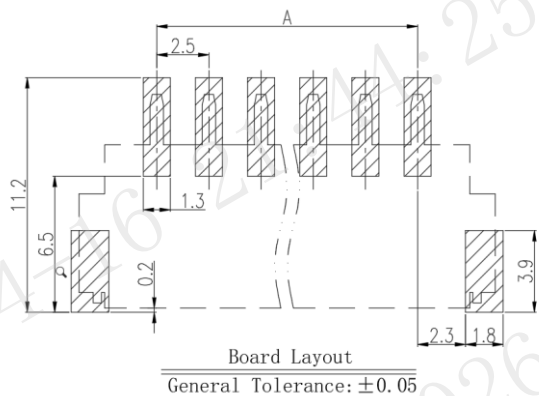

3 位 H 型卧式带扣贴片安装

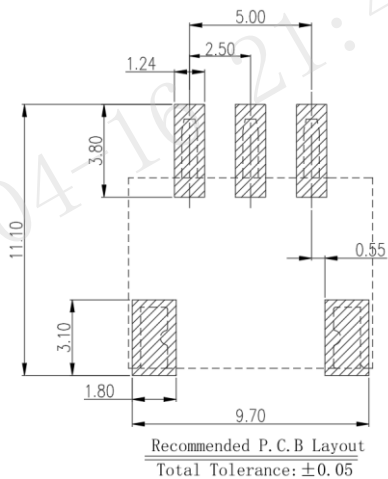

3 位 C 型卧式沉板贴片安装

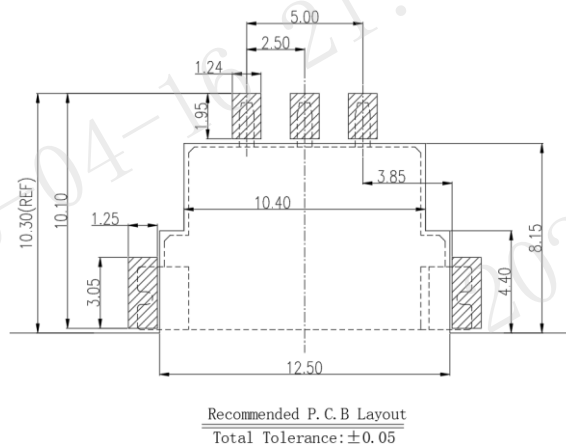

4. 端子适用导线 Applicable conductor of terminal



浙江珠城科技股份有限公司

ZHEJIANG ZUCH TECHNOLOGY CO., LTD

产品系列

XH 系列

文件名称
Document name

产品应用规格书
Product Application Specification

页码 page

6-10

型号 Part No.	压线角尺寸 crimping foot size	导线规格 Wire	导体截面面积 Cross-sectional area	线皮直径 Insulation diameter
TP2502J-1301	中脚 medium foot	22~24#AWG	0.3mm ² ~0.2mm ²	Φ1.9mm MAX.
TP2502J-1302	低脚 low foot	26#AWG	0.15mm ²	Φ1.9mm MAX.
TP2502J-1303	高脚 high foot	20#AWG	0.5mm ²	Φ1.3mm MAX.

5. 产品压接指导 Product crimping guidance

5.1 压接要求 Crimping requirements



浙江珠城科技股份有限公司

ZHEJIANG ZUCH TECHNOLOGY CO., LTD

产品系列

XH 系列

文件名称
Document name

产品应用规格书
Product Application Specification

页码 page

7-10

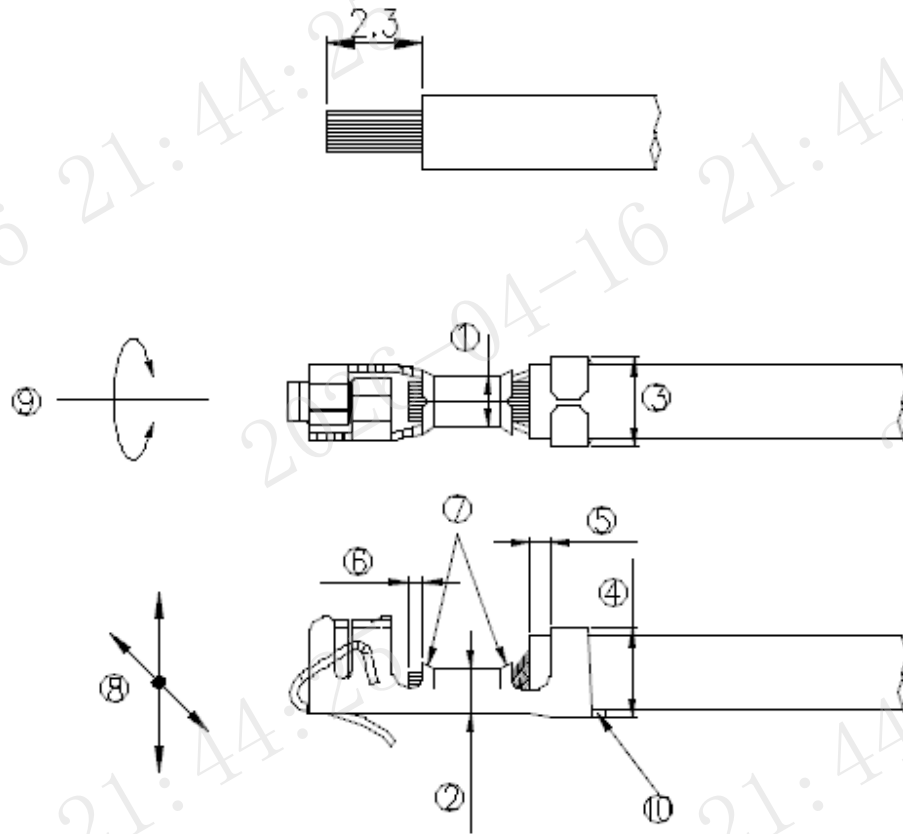

序号 No.	压接检查要素 Crimping inspection elements	技术要求 Requirement
(1)	导线剥线长度 Strip length	2.3±0.1mm
①	线芯段压接宽度 (CCW) Conductor crimping width	见表 1 (仅供参考) See table 1 (For reference only)
②	线芯段压接高度 (CCH) Conductor crimping height	
③	线皮段的压接宽度 (ICW) Insulation crimping width	
④	线皮段的压接高度 (ICH) Insulation crimping height	
⑤	压线脚衔接段 Transition Area	线芯和线皮需同时可见 Conductors and wire insulation both visible in translation area.
⑥	导线末端漏出长度 Wire Brush	0.5±0.2mm



浙江珠城科技股份有限公司

ZHEJIANG ZUCH TECHNOLOGY CO., LTD

产品系列

XH 系列

文件名称
Document name

产品应用规格书
Product Application Specification

页码 page

8-10

⑦	喇叭口 Rear Bellmouth	喇叭口必须可见且不可压伤线芯 The rear bellmouth must be visible and cannot crush the wire core
⑧	压接后弯曲度 Straightness	四向弯曲度 $\leq 3^\circ$ Four-way bending $\leq 3^\circ$
⑨	压接后扭曲度 Twist and Roll	$\leq 5^\circ$
⑩	余料长度 Surplus length	0-0.3mm

Table 1:

单位 Unit: mm

产品型号 Part No.	适用线型 Applicable linetype	线芯段压接 宽度 CCW	线芯段压 接高度 CCH	UL1007 线皮段的 压接宽度 ICW	UL1007 线皮段的 压接高度 ICH
TP2502J-1301	22AWG	1.27 \pm 0.05	0.74 \pm 0.05	1.9 \pm 0.1	2.0 \pm 0.2
	24AWG		0.67 \pm 0.05		1.9 \pm 0.2
TP2502J-1302	26AWG	1.17 \pm 0.05	0.68 \pm 0.05		1.8 \pm 0.2
TP2502J-1303	20AWG	1.4 \pm 0.05	0.87 \pm 0.05		2.1 \pm 0.2

备注：此压接标准仅供客户参考用，实际的压接高度取决于客户使用的压接模具和压接刀片。

Remarks: This crimp standard is for customer reference only. The actual crimp height depends on the crimp die and crimp blade used by customer.

5.2 检测方法 Check method

5.2.1 尺寸检查:如图一, A 为线芯段测量位置, B 为线皮段测量位置。

5.2.1 Dimension inspection: as shown in Figure 1, A is the measurement position of core section and B is the measurement position of insulation section.



浙江珠城科技股份有限公司

ZHEJIANG ZUCH TECHNOLOGY CO., LTD

产品系列

XH 系列

文件名称
Document name

产品应用规格书
Product Application Specification

页码 page

9-10

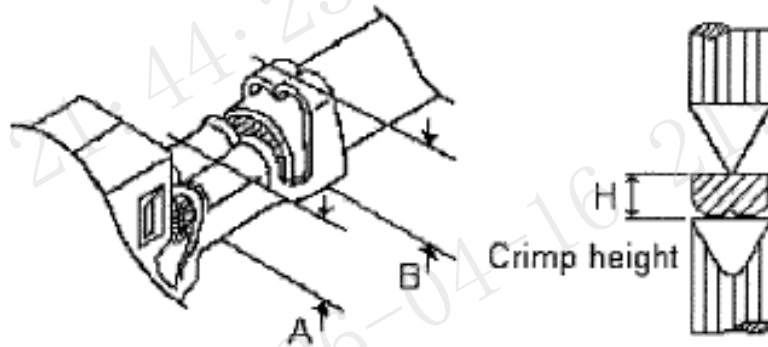

图一 Figure 1

测量 A 尺寸时，应以千分尺测量，测量区域为压接形状的正中位置，以保证测量值的准确性，如图一右侧视图所示，测量结果应符合“表 1”。

测量 B 尺寸时，可用游标卡尺测量，外形尺寸符合“表 1”即可。

Use a micro caliper to measure dimension A, to assure the accuracy of the conductor crimping height measurement, measure the crimp height at the center of barrel as show in the right of Figure 1, the measurement shall be in compliance with table 1.

A vernier caliper to measure dimension B, the measurement shall be in compliance with table 1.

5.2.2 剖面分析 Crimping cross section analysis.

线芯段要求：

端子在制作破面时，应注意避开端子本身的浅槽，应垂直压线脚轴线。

Wire conductor requirement after crimping:

When making the cross section, make sure to keep away from the serration area of the terminal, and the cross section shall be vertical to the axis.



浙江珠城科技股份有限公司

ZHEJIANG ZUCH TECHNOLOGY CO., LTD

产品系列

XH 系列

文件名称
Document name

产品应用规格书
Product Application Specification

页码 page

10-10

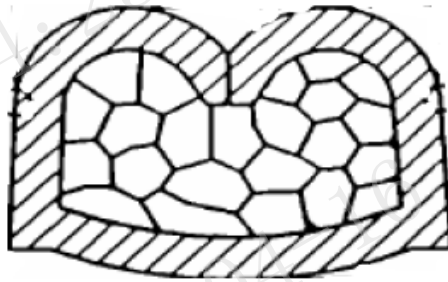

1. 压接剖面应无孔隙，导线芯数等于压接前的芯数，每根线芯均应发生变形；
2. 不可有孤岛现象。

1. Cross section must be without hole, the number of cored wires shall be same to the qty before the crimping, and the every cored wire shall be deformed after crimping.

2. Isolated island phenomenon is not allowed.

线皮段要求：

如下图所示，端子压线脚应固定导线，且不可刺入线皮接触芯线。

Wire insulation requirement after crimping:

The insulation barrel shall hold the lead wire securely without thrust into the wire insulation and damage the cored wire.

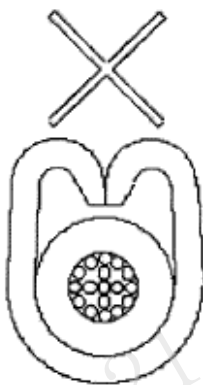

NG

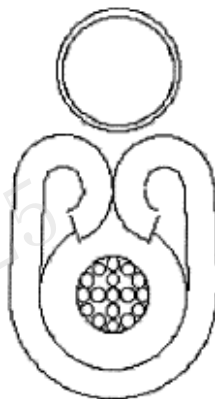

OK

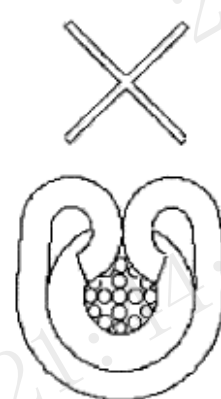

NG